

Type S21LB12D-02ZP-...

The single-axis controller S 21 is a rugged switching device according IEC/EN 60947-5-1 for electro-hydraulic applications. The modular design enables the switching device to be used universally. The S 21 is resistant to oil, maritime climate, ozone and UV radiation.

**Contact complement 2 A 250 V AC 15 or 3 A 24 V DC 13**

Mechanical life S 21 6 million (operating cycles)  
 Mechanical life SS 21 10 million (operating cycles)  
 Permissible ambient temperature Operation -40° C to +60° C  
 Storage -50° C to +80° C

Climate resistance  
 Damp heat constant IEC 60068-2-78  
 Damp heat cyclic IEC 60068-2-30  
 Degree of protection front IP 54 IEC/EN 60529  
 Technical data see catalog 4/100  
 Description data see catalog 4/020

Spindle block with schematic representation of the master controller installation and deflection directions.  
 Version shown for left-hand side installation (right-hand side installation is mirror image).

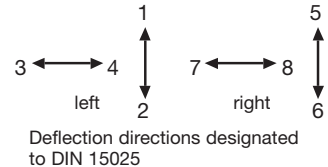

Pos.	S 21	Type expansion		Weight gramm	Type	Price EURO
1				650	S 21	
2				650	SS 21	
3						
4						
5						
7.1	Single-axis controller left (dir. 1-2, 3-4)				L	
7.2	Single-axis controller right (dir. 5-6, 7-8)				R	
20	Control-handle with knob solid					
21	Control-handle with latch for mechanical zero interlock					
21.1	by lifting			50	M	
21.4	by pushing down			50	MN	
21.5	Mechanical zero interlock with command devices see catalog 1/274					
22	Control-handle with dead man's button 1 NO			100	T	
23	Control-handle with signal button 1 NO			100	H	
24	Control-handle with push button 1 NO			110	D	
25	Control-handle with flat push button 1 NO			110	DV	
26	Control-handle with palm grip B 1			40	B 1	
27	Control-handle with palm grip B 1 with push button top 1 NO			60	B 1T	
28	Control-handle long or short					
28.2	-20 mm				S5	
28.3	+20 mm				S8	
29	More knobs, grips and T-grips with and without signal devices see catalog 1/270ff					
30	Masterswitch (contact) switching sequence 5-0-5		No. of contacts 3	300	02	
31			5	330	03	
32			7	360	04	
33	Switching program according contact-arrangement MS... see catalog 4/001		9	390	05	
34	or to your contact-arrangement	A...				
35						
36						
38	Spring return in 0-position (for each direction)			20	Z	
39	Friction brake adjustable (for each direction)			20	R	
40	Potentiometer e.t.c. each direction with mounted Wire-wound potentiometer T 130, with centre tap, 1,5 Watt wiper current max. 10 mA resistance 2 x 0,5k $\cong$ P021, 2 x 1k $\cong$ P022, 2 x 2k $\cong$ P023, 2 x 5k $\cong$ P024, 2 x 10k $\cong$ P025	...P02 $\square$		70	P	
41	Prepared for mounting potentiometer shaft 6 mm adjusting-angle 2 x 150°				(P)	
42	Prepared for mounting potentiometer e.t.c. adjusting-angle variable.				(P)	
43	more Potentiometer e.t.c. see catalog 1/240ff	C..., P...				
50	Steel sheet housing B 200 masterswitch Gr. 05			1300	B	
51						
52	More housing see catalog 1/350					
60	Indicating labels not engraved with 2 arrows					
61	Engraving, each 10 characters					
70	Command and indicating devices see catalog 1/360					



T = dead man's button  
H = signal button  
M = latch for mechanical zero interlock

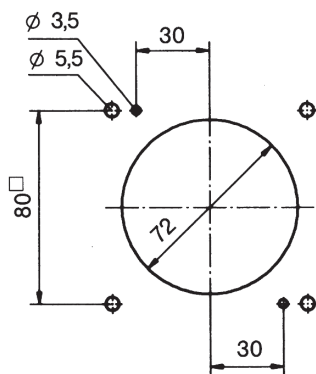
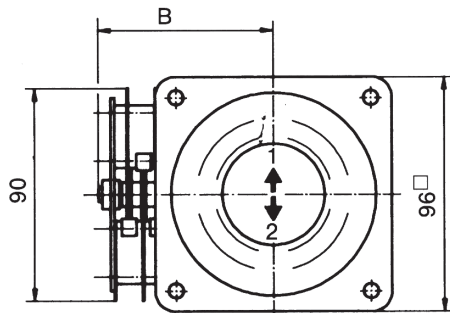
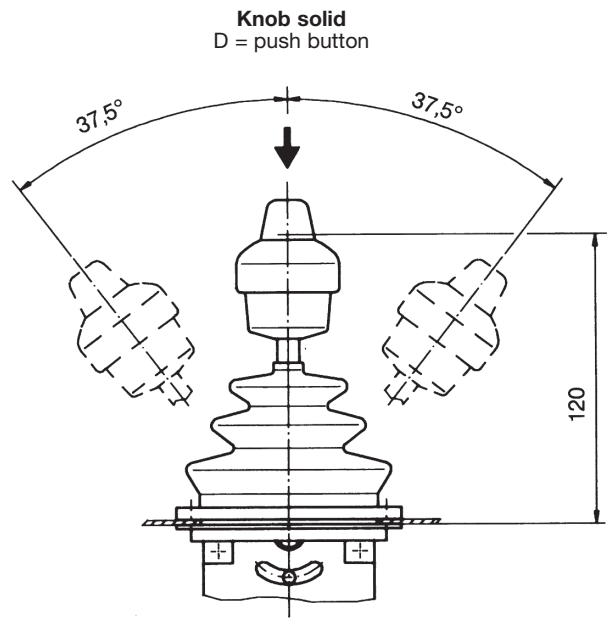
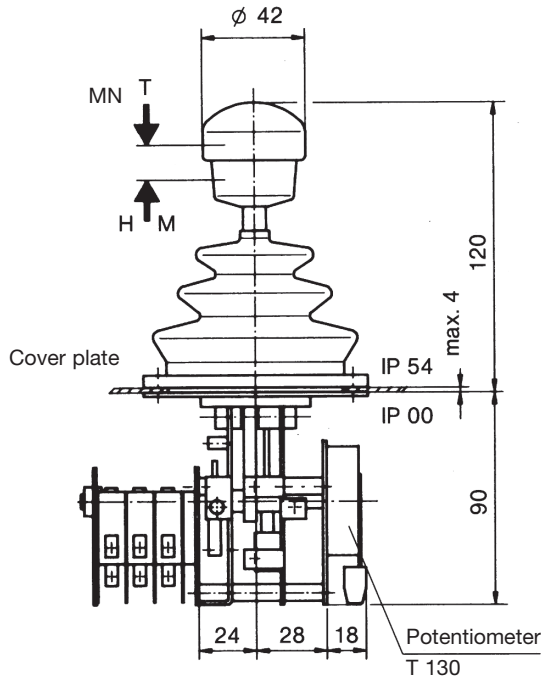

Hole pattern

Palm grip B 1

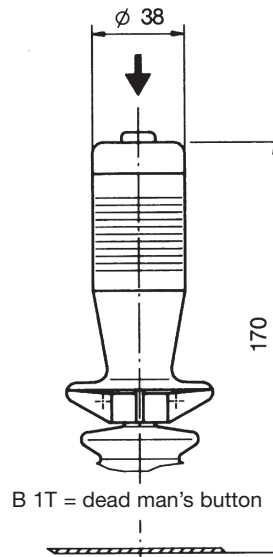

Type	No. of contacts	Dimension B
02	3	62
03	5	72
04	7	83
05	9	93

