



CUSTOMER: _____ **DATE:** _____

CONTACT: _____ **PHONE:** _____ **FAX:** _____

1) APPLICATION

- INDOOR OUTDOOR MARINE ENVIRONMENT MOBILE EQUIPMENT OVERHEAD CRANE/HOISTING CRANE CHAIR
- PORTABLE EQUIPMENT FOOT PEDAL OTHER _____

2) CONTROLLER SIZE & DURABILITY

- MINIATURE: V10 H100 H7 V14 V20 S14 MEDIUM: V11 V8 D8
- SMALL: V5 VV5 S2 S21 S22 S23 S24 N6 LARGE: V3 V6 VV6 D64 DD64 K2

3) CONTROLLER FUNCTIONS

SINGLE AXIS (PICK 1 OF 3 ITEMS BELOW)

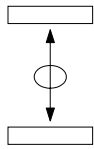

STANDARD BI-DIRECTIONAL

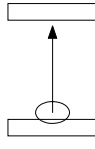

FULL TRAVEL UNI-DIRECTIONAL

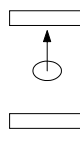

CENTER TO END UNI-DIRECTIONAL

DUAL AXIS

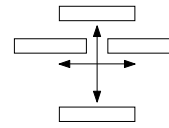

MULTI AXIS

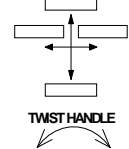

TWIST HANDLE

4) SWITCH SPECIFICATIONS

LEFT HAND MOUNTING

- | | |
|--|--|
| VOLTAGE _____ AC/DC | CURRENT _____ AMPS. |
| DIRECTION 1&2 | DIRECTION 3&4 |
| NUMBER OF CONTACTS _____ | NUMBER OF CONTACTS _____ |
| STEPLESS OR STEPS _____ | STEPLESS OR STEPS _____ |
| <input type="checkbox"/> SPRING RETURN | <input type="checkbox"/> SPRING RETURN |
| <input type="checkbox"/> FRICTION BRAKE | <input type="checkbox"/> FRICTION BRAKE |
| <input type="checkbox"/> POTENTIOMETER _____ | <input type="checkbox"/> POTENTIOMETER _____ |
| <input type="checkbox"/> ELECTRONICS | <input type="checkbox"/> ELECTRONICS |

RIGHT HAND MOUNTING

- | | |
|--|--|
| VOLTAGE _____ AC/DC | CURRENT _____ AMPS. |
| DIRECTION 5&6 | DIRECTION 7&8 |
| NUMBER OF CONTACTS _____ | NUMBER OF CONTACTS _____ |
| STEPLESS OR STEPS _____ | STEPLESS OR STEPS _____ |
| <input type="checkbox"/> SPRING RETURN | <input type="checkbox"/> SPRING RETURN |
| <input type="checkbox"/> FRICTION BRAKE | <input type="checkbox"/> FRICTION BRAKE |
| <input type="checkbox"/> POTENTIOMETER _____ | <input type="checkbox"/> POTENTIOMETER _____ |
| <input type="checkbox"/> ELECTRONICS | <input type="checkbox"/> ELECTRONICS |

5) ELECTRONICS

A) VALVE SPECIFICATIONS

VALVE MANUFACTURE _____ MODEL NUMBER _____

SUPPLY VOLTS: _____ VDC COIL RESISTANCE: _____ OHMS THRESHOLD: _____ mA MAX. OUTPUT _____ mA

SINGLE COIL DUAL COIL FLOW CONTROL SWITCHES FOR DIRECTIONAL VALVES PWM FREQUENCY: _____ Hz

B) SIGNAL OUTPUTS

SUPPLY VOLTS: _____ VDC 4-20mA 0-20mA 0-10V -10V to +10V OTHER _____

C) OPTIONS FOR BOTH

SINGLE MAX. (A ADJ.) DUAL MAX. (A & B ADJ.) DUAL RANGE _____ mA RAMP TIME _____ SEC.

6) HANDLE TYPE

- STANDARD KNOB MECHANICAL INTERLOCK PUSHBUTTON DEADMAN PUSH DEADMAN PULL DEADMAN
- PALM HANDLE _____

7) NAMEPLATE SPECIFICATIONS

STANDARD NAMEPLATE _____ SPECIAL NAMEPLATE (ATTACH LAYOUT DRAWING OR SPECIFICATIONS)

8) ENCLOSURE

- GENERAL PURPOSE WEATHERPROOF CORROSIVE RESISTANT (PLASTIC) PORTABLE CONSOLES
- ENCLOSURE DIMENSIONS L= _____ W= _____ H= _____ TS1 TS2

9) NOTES

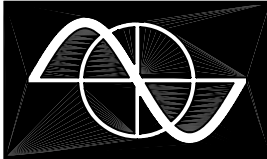

THE V14 IS A COMPACT MASTER SWITCH DESIGNED FOR PORTABLE APPLICATIONS.
IT IS SMALL, LIGHTWEIGHT AND SOLID IN DESIGN.
IT IS BUILT FOR 6 MILLION OPERATIONS.
IT IS OIL, OZONE, UV AND SALT ATMOSPHERE (OCEAN CONDITION) RESISTANT.
CONTACTS ARE RATED AT 2A 250V AC 15 RES. 1A 24V DC 13 DEGREE OF PROTECTION FRONT: IP65

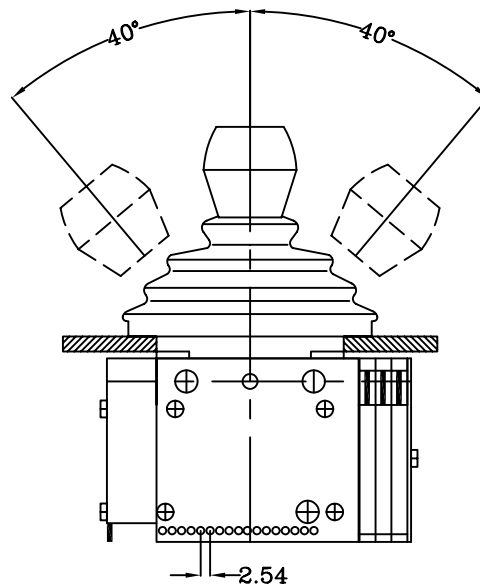
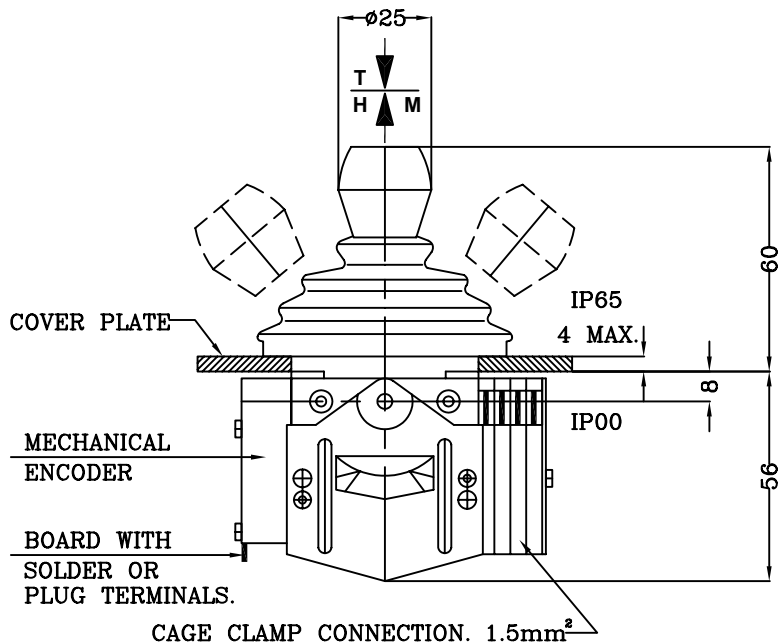

TYPE	NO. OF CONTACTS	DIMENSION B
01	2	36
02	4	45
03	6	54

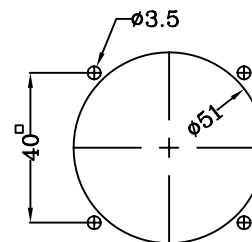
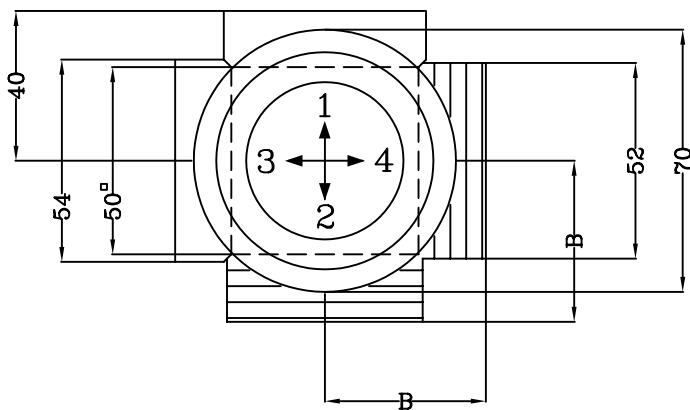

PANEL CUT OUT

V14	V14-BASIC MASTER SWITCH
○	X-STANDARD HANDLE
○	T-DEAD MAN TO PRESS
○	P-DEAD MAN TO PULL
○	M-MECH. INTERLOCK IN 0 POSS.
○	1-SWITCHING GATE #1 I
○	2-SWITCHING GATE #2 +
○	3-SWITCHING GATE #3 □
○	4-SPECIAL SWITCHING GATE
○	CONTACT ARR. DIR. 1-2
○	A-Z-FROM SHEET 20.2.1
○	O-SPECIAL CONTACT ARRANGEMENT
○	X-IF NOT REQUIRED
○	ENCODER WITH 5 x 10 ⁶ SWITCHING CYCLES
○	0.5 WATTS. WIPER CURRENT Ima.
○	1-2-MEC 1-2 CONTACT 'N' PAGE 20.2.1
○	COND. PLASTIC POT. 2 x 10K OHM
○	1-7-MEC 1-7 CONTACT 'N+M'
○	COND. PLASTIC POT. 2 x 5K OHM
○	1-6-MEC 1-6 6 BIT GRAY CODE
○	1-6-5-MEC 1-6-5 4-20ma. 24V DC
○	1-6-8-MEC 1-6-8 0-20ma. 24V DC
○	X-IF NOT REQUIRED
○	CONTACT ARR. DIR. 3-4
○	A-Z-FROM SHEET 20.2.1
○	O-SPECIAL CONTACT ARRANGEMENT
○	X-IF NOT REQUIRED
○	ENCODER WITH 5 x 10 ⁶ SWITCHING CYCLES
○	0.5 WATTS. WIPER CURRENT Ima.
○	1-2-MEC 1-2 CONTACT 'N' PAGE 20.2.1
○	COND. PLASTIC POT. 2 x 10K OHM
○	1-7-MEC 1-7 CONTACT 'N+M'
○	COND. PLASTIC POT. 2 x 5K OHM
○	1-6-MEC 1-6 6 BIT GRAY CODE
○	1-6-5-MEC 1-6-5 4-20ma. 24V DC
○	1-6-8-MEC 1-6-8 0-20ma. 24V DC
○	X-IF NOT REQUIRED
○	1-M-STANDARD NAMEPLATE. SECT.
○	X-IF NOT REQUIRED 20.1
○	O-SPECIAL NAMEPLATE
○	MARK IN CHART
○	G-GENERAL PURPOSE ENCL.
○	W-WEATHERPROOF ENCL.
○	O-OPEN TYPE SWITCH

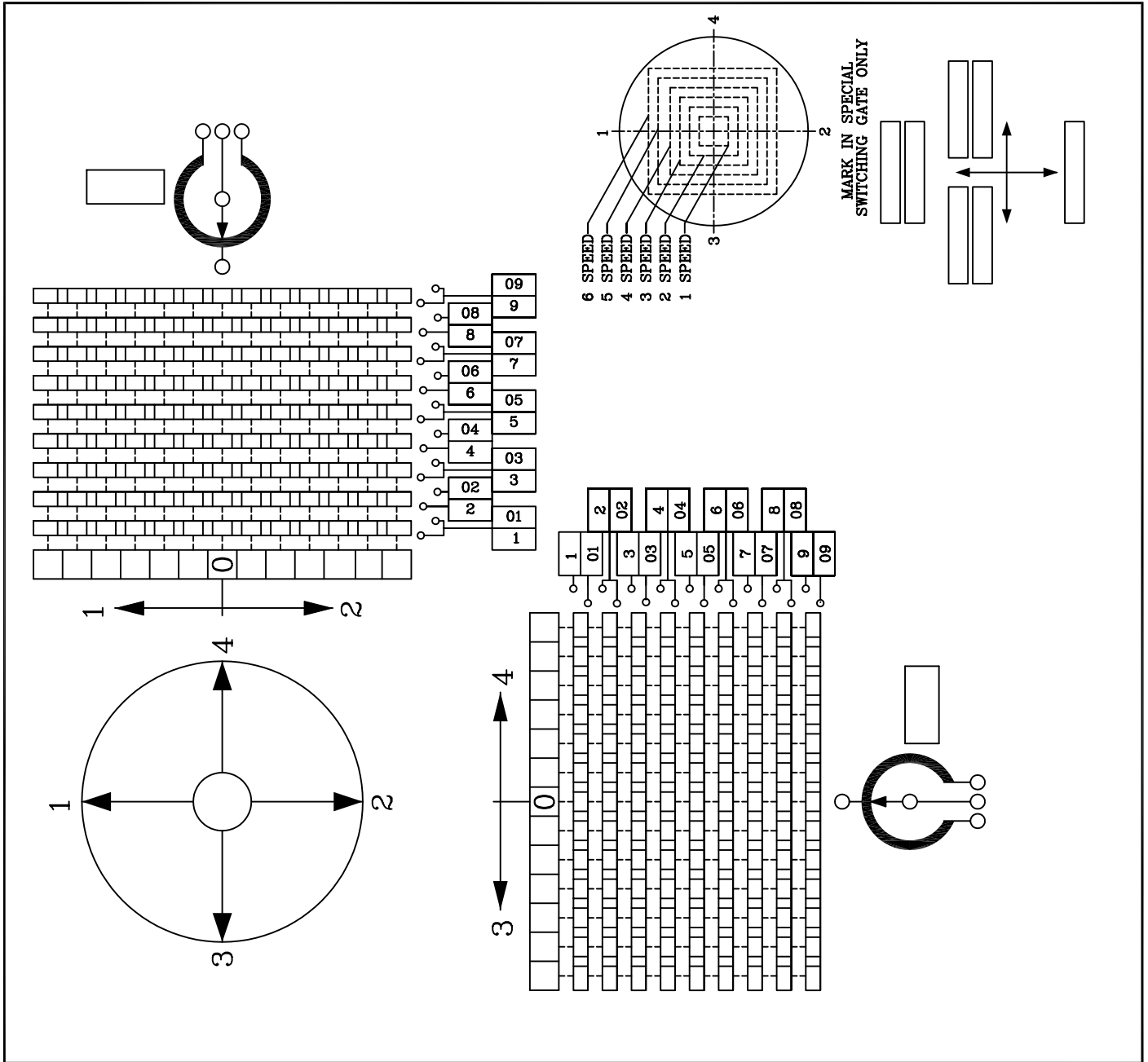

GESSMANN V14 MASTER SWITCH		JOB #
DATE:	FROM:	
NAME:		